



## COAIRO CD200 USER MANUAL

INSTALLATION BY A HVAC PROFESSIONAL IS RECOMMENDED

The CoAiro CD200 is a split system dehumidifier with sensible cooling that is integrated into the heating and cooling system to provide the ultimate in comfort, health and property protection

## Table of Contents

Important Notes	1
Features	1
Safety Notes	1
Warranty Registration	2
Parts Included	2
Specifications	3
Installation Dehumidifier	4
Condenser Setup	6
Charging the System	12
The On-Board De-humidistat	13
External Control	13
Maintenance	14
Dehumidifier Spare Parts	15
Condensing Unit Spare Parts	15
Limited Warranty	16
Warranty Exclusions	17

## 1. Important Introduce

The CoAiro CD200 is a split system dehumidifier with sensible cooling that is integrated into the heating and cooling system to provide the ultimate in comfort, health and property protection through:

- Dehumidification
- Sensible Cooling
- Fresh Air Ventilation (Optional)
- Air Filtration

The two-piece design allows the sensible heat load generated from dehumidifying the house to be released in the outside condensing unit, thus eliminating additional cooling and reducing air conditioner run time.

## 2. Features

- It is made with a low voltage control system.
- It has the R410A refrigerant, which is generally environmentally friendly.
- It features an auto-restarting operational system after power outages.
- It used the standard MERV-11, which offers superior air filtration.
- The device has a quiet operation.
- It is designed with a long life and high-efficiency impeller.
- It has an optimized and perfectly patented air-to-air heat exchanger.
- The device brags of industry-leading effectuality.  
4,300 BTU cooling.

## 3. Safety Notes

- This type of dehumidifier is designed in such a way that it is suitable for indoor installation in a room that is perfectly protected from flooding and rain.
- The condensing unit must always be protected from elements such as snow, rain, and sunlight although the device can be installed outdoors.
- Ensure that the discharge air is not directed at people, or over water in spa and pool areas.
- Install dehumidifier according to all applicable local, state, and national codes.
- If the device is meant for use near water, spa or a pool, make sure that there are no possible chances of the unit being splashed or/and falling into the water. Also, make sure that it is plugged into an outlet that is protected by the GFI (Ground Fault Interrupt) circuit.
- Always connect your dehumidifier using a grounded, dedicated electrical connection that is GFCI protected with at least 15 amp capacity.
- The use of any other type of wiring will void your warranty.

- Be sure to follow your GFCI maintenance instructions. you will typically need to test the operation of the trip circuit monthly.
- For ease of testing and operation, it may be helpful to put the test switch and indicator lights in a convenient location.
- The design of the dehumidifier is suitable for indoors space that is protected from any forms of flooding or rain.
- It is important to install the dehumidifier in a room that has enough space. This is to allow you to access the side and/or back panels easily for service and maintenance purposes.
- Your dehumidifier should only be repaired by a qualified technician.
- Do not insert objects or your fingers into the inlet or discharge.
- Do not use water to clean the exterior of the dehumidifier. To clean unit, unplug from power, then use a damp cloth to wipe the exterior.
- Do not stand on dehumidifier or place objects on it.
- Unless otherwise noted, all maintenance should be done with the unit power off.

## 4. Warranty Registration

Prior to installation of the unit, write down the serial number and date of purchase. You will need this information if you need assistance in the future. The data label on the side of your unit has the necessary information.

**Model Number: CoAiro CD200**

**Serial Number:** \_\_\_\_\_ **Date of Purchase:** \_\_\_\_\_

For additional questions concerning your dehumidifier:

- Contact your installing contractor
- Contact US: [support@coairo.com](mailto:support@coairo.com)

## 5. Parts Included

- The CoAiro CD200 Leveling Feet.
- The CoAiro CD200 Installation Instructions.
- The CoAiro CD200 Condensing Unit.
- The CoAiro CD200 Dehumidifier.

## 6. Specifications @ 80°F/60% RH

DEHUMIDIFIER		CONDENSER	
<b>Capacity@80°F/60%RH:</b>	200 Pints Per Day	<b>Current Draw</b>	9.7 Amps
<b>Airflow @ 0.0" SP</b>	300 CFM	<b>Minimum Circuit Ampacity:</b>	20 Amps
<b>Operating Temp. Range</b>	33-105°F	<b>Maximum Fuse / Breaker:</b>	20 Amps
<b>Operating Relative Humidity Range:</b>	36%-90%	<b>Refrigerant:</b>	R410A
<b>COP:</b>	2.8 L/kWh	<b>Operating Range:</b>	40°F Min, 115°F Max
<b>Refrigerant:</b>	R410A	<b>Power Supply:</b>	115V/60Hz /Single Phase
<b>Amperage Usage:</b>	7.6 Amps	<b>Dimensions:</b>	
<b>Power Supply:</b>	115V/60Hz /Single Phase	<b>Width:</b>	20.25"
<b>Outlet Requirement:</b>	15 Amp, 3 Prong, GFCI	<b>Height:</b>	21.75"
<b>Sound Level:</b>	60 dBa	<b>Length:</b>	38"
<b>Dimensions:</b>		<b>Weight:</b>	109 lbs
<b>Width:</b>	20.25"	<b>Power Cord:</b>	Hard-Wired
<b>Height:</b>	21.75"		
<b>Length:</b>	38"		
<b>Weight:</b>	109 lbs		
<b>ETL Listed:</b>	YES		

## 7. Installation Dehumidifier

The CoAiro CD200 can be installed in various locations in order to meet the needs of the client. However, it is important to observe the factors highlighted below during the installation process:

- The device is designed to best suit indoor installation in a room that is protected from flooding and rain.
- Make sure you install the device in a room with enough space to allow easy access to the side and back panels during service and installation. The space should also allow easy access to the filter cover panel.
- You should ensure that the air discharged by the device is not directed over water in the pool areas, or at people.  
Make sure that there are no possible chances that the device could be splashed or fall into the water. Also, ensure that it is plugged into a GFI (Ground Fault Interrupter).
- You should never use the device on a table or a bench.
- You should not place the device directly to structural members.
- Make sure you provide isolation to reduce operational noise and/or vibration.
- The drain pan should always be placed beneath the dehumidifier unit if it is located above a room where water leakage is more likely to occur.
- Place the device on supporters that raise its base to at least 6" above the top flanges on the drain pan below it. Raising the dehumidifier will help the device to drain water freely with gravity.
- The device can be suspended using a steel hanger or any other suitable alternative from structural members, the unit should be supported from beneath. Ensure that you do not hang from ends or sides.
- Make sure that you place a drain pan beneath the dehumidifier if it is suspended on top of a finished area or a space where water leakage is more likely to occur.

### 7.1 Electrical Requirements

The device plugs into a NEMA rated receptacle. The number of Amps drawn by the device may vary depending on the operational conditions. In most cases, a GFI protected circuit is necessary. It is important to install the remote control panel in the central area of the room where it will be able to sense the RH of the room on turning it on.

It is important to install the remote control panel in the central area of the room where it will be able to sense the RH of the room on turning it on.

**CAUTION:** In order to maintain proper drainage, it is advisable that the unit should be mounted such that the drain outlet is 4" or more above the floor drain, and must be totally supported beneath the base.

### 7.2 Plug Holes Using

- Coil the control panel and the dehumidifier. Make sure that you safely route the control wiring to help avoid damage during the installation process.
- Make sure you do not cross the wires when you are connecting the device and the remote control panel too.
- In most cases the remote control panels of the CoAiro CD200 are powered by the low voltage (24 VAC). It must never be connected to any sort of high voltage circuit. The remote control and terminals are numbered and labeled to prevent confusion. Make sure you read the electrical schematic available inside the access panel of the device or in this manual before you make any control connections.

**CAUTION:** In order to maintain proper drainage, it is advisable that the unit should be mounted such that the drain outlet is 4" or more above the floor drain, and must be totally supported beneath the base.

### 7.3 Condensate Water Removal

In normal cases the condensate drain by the aid of gravity through the drain port. It is advisable that you make use of the 3/4" male PVC NPT pipe. Also, rout the drain pipe and ensure it is draining well. If possible, install a trap too. You should always be careful when installing the drain pipe to the drain port. You can use an adjustable wrench to safeguard the drain port. In addition, an optional water pump kit can be installed in a case where a lift is necessary for disposing of the condensate. You can order the condensate pump kit from CoAiro Dry.

During the installation of the drain hose ensure that the base of the device is at least 6" above the ground. After this, coil the drain hone beneath itself or just position a spacer to lift the hose at least 1" above the ground after the hose gets in contact with the ground. This process will create a trap that makes sure that the unit drains well.

### 7.4 Hanging Diagram



## 7.5 The P/N 4028607 Supply Duct Kit

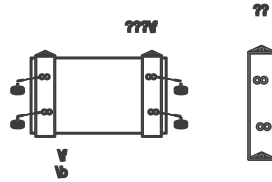

### Supply Duct Kit (P/N 4028607)

A factory designed supply kit can be bought to match the 10" ducting to both inlet and outlet of the CoAiro CD200.

You can contact the manufacturer or may find it at your local dealer's store.

### The P/N 4028610 Return Duct Kit

A factory designed return kit can be bought to match the 12" ducting of the device.

You can call the manufacturer or may find it at your local dealer's store.

The condensing unit demands that a dedicated 20 Amp 120VAC circuit capacity. Makes sure you install a well-sized branch circuit disconnect that is 20 Amp within the sight of the condenser unit. The installer should supply the power wiring for the purpose of condensing unit. In any case, the power wiring should have a minimum of 20 Am circuit Ampacity, and it should be run through a rain-tight conduit. The condensing unit should be grounded as per the applicable codes.

## 8. Condenser Setup

### 8.1A Location

- The condensing unit is designed to be installed outdoors in a space that is protected from extreme weather (rain, wind, etc.). Do not place the condensing unit in direct sunlight.
- Place the condensing unit at least 1" above ground level.
- Place the condensing unit as close as possible to the dehumidifier to minimize the length of the connecting lines. The maximum line set length is 50 feet.
- Ensure the mounting of the condensing unit can withstand strong winds and earthquakes when mounting above ground level.
- The condensing unit may be mounted to a wall (with brackets) or placed on a roof.
- Mount the base of the condensing unit to a sturdy level pad (or bracket) using 3/8" (10mm) bolts. Avoid directing the discharge air at people.
- If used near a water source; be certain there is no chance the dehumidifier could fall into the water or get splashed and that it meets NEC standards.

- DO NOT use the condensing unit as a bench or table.
- Do not place the condensing unit where the sound and vibration caused by running the unit will cause a nuisance. Vibration dampening material may be installed between the condensing unit base and the mounting pad if required.
- Allow sufficient clearance to handle the unit's overall dimensions.
- Place the condensing unit where there is adequate space for the unit and the air required by the unit.
- Install the condensing unit with space to access the top and side panels for maintenance and service.

### 8.2 The Procedure of Field Wiring the Condensing Unit

- First of all, take off the top panel, by simply removing the screw present on the dehumidifier securing the condensing unit.
- Second, loosen the two-strain relief bloc screws.
- Insert the control and power wires via the strain relief block.
- Forth, connect the control wires and the power supply wires to the matching terminals on the terminals board.
- Make sure you ground the condensing unit with the observance of the national and local electrical codes.
- Ensure that you secure the control and power wires to the strain relief block by simply tightening the available screws.
- Lastly, reinstall the top panel by inserting the screw that secures the condensing unit.

### 8.3 The Line Set

- You should ensure that the lines are perfect for use with the R410a.
- You should never crush the line sets and ensure that you may only allow an average bend radius of 2 inches.
- Ensure that the ends of the line sets are well-covered to avoid debris and dirt from penetrating the lines during the installation process.
- Secure the lines nearer to the structure using the isolating hardware to avoid any chances of vibration transmission to the entire building.
- Isolate and seal the openings where the line are routed into the building.
- Make sure you insulate the suction (gas) line set to prevent chances of water condensation occurring within the suction line.
- Ensure that you fully flush the line sets with an inert gas prior to and/or during the brazing process to prevent chances of oxidation occurring in the line sets.
- Ensure that you release the inert gas while holding the charge and also remove the plugs connecting to the dehumidifier lines prior to brazing.
- You should never overheat the line sets connected to the device or the condensing unit during the brazing process.
- You should be aware of the most appropriate locations of the condensing (outdoor unit) and the dehumidifier (indoor unit) when installing the lines.

**Warning:**

The POE (Polyester) oils used by the HFC-410A refrigerant system absorb moisture quickly. It is thus; very essential to keep the refrigerant system closed all the time. Ensure that you do not remove service valve stub caps or the line set caps until you are ready to complete the connections. In a case where you are using high-pressure gas, for instance, dry nitrogen to pressurize the air conditioning system or refrigeration, it is important to maintain the pressure at 1 to 2 PSIG.

**Caution:**

Brazing flux and alloys contain materials that are hazardous to the health. You should, therefore, avoid breathing in the fumes or vapors released from the brazing operations. It is important that you perform the operation in a well-ventilated space. Put on protective goggles and gloves or use the face shield to protect your body against burns. Ensure that you wash your hands using soap and running water after you handle the brazing flux and alloys. In order to prevent the stripping of the numerous caps utilized, an averagely sized wrench must be used and should be fitted snugly over the cap prior to tightening. Also, give the braze joint some time to cool before you remove the wet rag from the service valve. You should be cautioned that temperatures that are above 250 degrees can damage the seals. You can use the silver alloy brazing rods that have five percent minimum silver alloy for the purpose of copper to copper brazing. In the case for copper to steel and copper to brass brazing, make use of the 45% minimum silver alloy.

**Warning:**

When using any dehumidifier you should be aware that the device bears along property safety hazards, explosion, and fire. If you fail to observe the safety measures highlighted in this manual, death, personal injury, and property damage is more rampant. Make sure that you never use oxygen to purge or pressurize refrigeration line sets. When oxygen is exposed to open flame or sparks it can cause an explosion and/or fire that could result in associated hazards. It is important to note that there is a service port in the CoAiro CD200 dehumidifier especially on the gas line, and on both stub tubes of the condensing unit. The service ports can be utilized to release and introduce nitrogen during the brazing process.

**Caution:**

The CoAiro CD200 dehumidifier is shipped from the manufacturer pressurized with the charge of inert gas together with a rubber plug in the lines. You can purge the inert gas out of the device by simply removing the rubber plugs present in the gas and liquid line to release the inert gas prior to connecting the line sets.

**Note:** In a case where there is no pressure in the CoAiro CD200 dehumidifier when the first plug is released, ensure that you check the device for leaks and damage before you proceed with the installation.

**You can make use of the following procedure to perfectly set the lines to the device:**

- First of all, purge the inert gas present in the device by simply removing the rubber plugs present in the gas and liquid lines to release the gas before you proceed to connect the line sets.
- Place a heat shield, for instance, a wet rag against the CoAiro CD200 dehumidifier and all around the piping stubs. Ensure that the heat shield is also in place to help protect the cabinet from any possible heat damage.
- If necessary, swage the gas and liquid lines to fit with the dehumidifier lines.
- Ensure that you purge the line set and the dehumidifier lines with the inert gas (dry nitrogen) to prevent any possible chances of oxidation during the brazing process. Make sure that you flow dry nitrogen throughout the lines set up to the dehumidifier lines.
- Next, braze the line sets up to the dehumidifier lines.
- Ensure that you remove the heat shield soon after brazing and enable the connected lines to cool.

**You can make use of the following procedure to connect the condensing unit to the line set:**

- Make sure that you first cut the line set to the desired length. Cover the cut ends of the line sets.
- Use the flare fittings that are included in the condensing unit to fit the lines onto the line set where needed.
- Carefully swage the gas lines and the liquid lines where necessary to ensure that they fit onto the line stubs and bind with flare fittings.
- Next, remove the service valve cores and caps.
- You can purge the lines with the inert gas such as dry nitrogen to prevent the occurrence of oxidation during the brazing process.
- Ensure that you braze the line stubs to the line sets.
- On completion of the above step, remember to apply a light coating of oil to the flare fittings and threads present on the condensing unit valves.
- Kick-start each and every flare nut on the parallel flare fitting present on the condensing unit valves using your hand, and make sure the threads are engaged well. Ensure you tighten the flare units well by hand.
- Carefully tighten the flare nuts to their corresponding flare fittings on the condensing unit valves.
- On completion of this procedure reinstall the service valve caps and cores.



## Leak Test the Dehumidifier and the Line Set

### The Manifold Set

During the process of checking the system charge, you can make use of the manifold gage, which features low loss of anti-blowback fittings. The manifold gage that is used with the HFC-410A refrigerant should be able to handle the higher system operating pressures. In general, the gages should be rated for utility with the high side operating pressure of about 0 to 800 psig, and the low side operating pressure of thirty inches of the vacuum to 250 psig. Anti-flutter gages and damper gages are often recommended. The gage hose, on the other hand, should be rated for use of up to 800 psig of pressure together with an average burst rating of 4000 psig.

### Caution:

The EPA (Environmental Protection Agency) prohibits the deliberate venting of HFC refrigeration during the disposal, repair, service, and maintenance of appliances. The approved methods of reclaiming, recycling or recovery should be observed.

### Warning:

In a case where you are using a high-pressure gas like dry nitrogen to pressurize air conditioning or refrigeration, it is recommended that you make use of a regulator that can perfectly control the pressure down to one or two PSIG.

### Caution:

The leak detector should be able to sense the HFC refrigerant.

### Warning:

The refrigerant gas may be harmful if inhaled. For that reason, the refrigerant must be recovered and used responsibly. Failure to observe this aspect may result in death or serious bodily injuries.

### When it comes to leak-testing the procedure highlighted below can be of great importance:

Connect the manifold HFC-410A gage set for the high-pressure hose to the suction gas line using the service port. By connecting the high-pressure hose to the gas line via the service port you will help to protect the manifold gage from the negative effects of high pressure during the leak testing process. Ensure that you cap the liquid line present on the manifold gage service port.

Ensure that all valves present of the manifold gage on the outdoor unit are closed. Connect an HFC-410A refrigerant cylinder to the center port present on the manifold gage set.

Position the cylinder of the HFC-410A refrigerant in such a way that it delivers vapor only. Open the valves on the refrigerant and ensure that the HFC-410A amount is at a maximum of 57g (two ounces) of refrigerant or at maximum 3PSI. Close the valve on the cylinder of HFC-410A and the valve present on the high-pressure manifold gage set.

Make sure that you disconnect the cylinder of the refrigerant from the manifold gage set.

Next, connect the cylinder of inert gas (dry nitrogen) using a pressure regulating valve to the middle port of the manifold set.

Adjust the inert gas (dry nitrogen) pressure regulator to averagely 150 psig. Then open the valve on the side of the manifold gage to pressurize the dehumidifier and line set.

Ensure that you close up the valve on the inert gas cylinder. Then close the valve present on the high-pressure side of the manifold set.

Give the system some time to rest.

Check all threaded and brazed joints for any possibilities of leaks using the leak detector designed to sense the HFC refrigerants.

After you complete the leak testing process, you may disconnect the inert gas cylinder from the middle port of the manifold gauge and also disconnect the high-pressure hose present on the manifold gage from the suction gas line service port.

### Evacuating the Dehumidifier and the Line Set

First of all, remove the valves from the service ports on the gas and liquid line stubs using the no-loss valve core removal gadgets.

Connect a quarter feet SAE in-line tee unto the gas stub valve core removal port.

Next, connect the manifold gage set low-pressure side to one of the ports present on the quarter feet SAE in-line tee.

Forth, connect the micron gage set to the remaining port of the SAE in-line tee. Connect the manifold gage set high-pressure side to the gas and liquid line stub service port.

Next, connect a vacuum pump to the middle port of the manifold gage set.

Then open the valve core removal tools.

Ensure that you open the low and high-pressure manifold gage set side and kick-start the vacuum pump.

After you evacuate for several minutes, close up the low and high-pressure sides of the manifold gage and check out the behavior of the entire micron gage. In a case where there is a rapid increase in pressure reading of the micron gage, it is evident that there are leaks in the system. In a case where this condition occurs, you may check the valve core removal tools, tee, hoses, and manifold gage set for the presence of leaks. If there is no leak found, ensure that you repeat the leak test process.

- Evacuate the dehumidifier and line set for a minimum of fifteen minutes then check if the micron gauge reads below five hundred microns.
- Ensure that you close the high and low-pressure sides of the gage set and stop the vacuum pump gradually.
- After this, install the valve core to the gas and liquid line stub service port.
- Finally, remove the vacuum pump from the middle port of the manifold gage and continue to the next section of charging the system.

## Charging the System

- You, first of all, calculate the number of HFC-410A needed by finding out the length of the line set and simply performing the calculation shown below:  $2.2oz + 11oz$  for every 10 feet of the line set length = to the total charge required.
- Ensure that you connect the refrigerant HFC-410A cylinder to the middle port of the manifold set, and position the cylinder of HF-C410A refrigerant to deliver strictly liquid.
- Next, open the HFC-410 cylinder valve.
- Fourth, place the cylinder of HFC-410A onto the refrigerant scale, and set the scale back to zero.
- Open up the manifold gage set low-pressure side and weigh the quantity of HFC-410A calculated above.
- Close up the valve on both the manifold gage set low-pressure side and the HFC-410A cylinder.
- Close up the valve present on the gas and liquid line stub core removal tool.
- Next, remove the low and high-pressure manifold gage set sides from the valve removal tools.
- Finally, install the valve core present in the liquid and gas line port by simply using the no-loss valve removal too
- Next, open up the valve present on the removal tool of the gas and liquid line stab.
- Open up the manifold gage set low-pressure side and weigh the quantity of HFC-410A calculated above.
- Close up the valve on both the manifold gage set low-pressure side and the HFC-410A cylinder.
- Close up the valve present on the gas and liquid line stub core removal tool.
- Next, remove the low and high-pressure manifold gage set sides from the valve removal tools.
- Finally, install the valve core present in the liquid and gas line port by simply using the no-loss valve removal tool.

## The On-Board De-humidistat

Usually, the humidity control of the CoAiro CD200 is an adjustable switch that usually closes in any case where the relative humidity of the air of the room in which the device is located increases to hit the RH set dial point. In normal cases, it is switched on when the relative humidity drops from four percent to six percent below the set point.

### The Average Relative Humidity Level per Setting

Humid – 80 percent to 90 percent relative humidity

Normal – 50 percent humidity (it is recommended)

Dry – 20 percent to 30 percent relative humidity

Typically, the dehumidifier runs until the RH (relative humidity) is decreased to the relative humidity dial setting.

## External Control

The dehumidifier is usually controlled by use of five different terminals. They include:

DMPR – It is meant for 24 volt AC power transformation neutral side. It is commonly read in color).

DEHU – It is the compressor and fan (dehumidification) control.

24V – It works for the transformer high side.

FAN – It serves as the fan control.

COM – It is meant for 24 volt AC power transformation neutral side. It is commonly white in color.

It is important to note that on-board de-humidistat should be set al through to humid.

Failure to do so may result in damage to the transformer.

Between the 24V leads and the COM/DMPR lead, a 40VA transformer is present. The low voltage power source is meant to power the relay coils that in turn control the compressors and fan. The 24VAC transformer may also be used to power the HVAC accessories that are external to the dehumidifier.

If you want to turn the dehumidifier on, it is important to make contact between the 24V and the DEHU terminals or make sure you turn the De-humidistat clockwise and towards the drier. And, when you want to turn the fan on, create contact between the FAN terminals and the 24V terminals. When you want to power the 24V HVAC accessory, ensure that you connect the accessory to the 24V terminal and the COM terminal.

It is important to note that an 18 GA wire may be needed between the external control and the CoAiro Cd200 dehumidifier.



## Maintenance

**WARNING:** You should never operate the CoAiro CD200 dehumidifier with a less effective filter or without a filter. In any case, the heat exchange coils that are in the unit could get clogged and end up with disassembly need to clean. Also, using the device with a non-compliant filter invalidates the warranty.

### Standard Air Filter

Normally, the dehumidifier is shipped with a standard MERV 11 which is a filter made of pleated fabric. The filter may only require service after six months of use. If you operate the unit with a not-reliable filter you will deter the efficiency and capacitor of the entire dehumidifier and this mistake may result in the unnecessary cycling on and off while on the defrost control state. In order to access the air filter, you will have to remove the filter access panel first. On removing the filter access panel the filter should be easily seen and may be removed by just pulling it straight from the dehumidifier. It is advisable that you change the impeller after at least every grow cycle.

### The Impeller Fan Oiling

In most cases, the impeller fan is factory lubricated and this can serve several years of operation, and no further oil may be required.

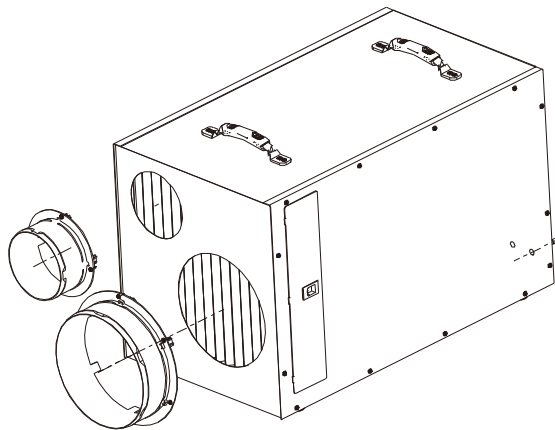

## Dehumidifier Spare Parts

Display/Control	
N-100	Main Control Board
N-101	Display Board
N-102	RH/Temp. Sensor
Internal Components	
N-1209	Compressor
N-1206	Compressor Capacitor
N-1208	Coil Assembly
N-1207	Condensate Pump Assembly

Fan Components	
N-1210	Fan Motor
N-1211	Complete Fan Assembly
N-1205	Fan Capacitor
Filter + External Components	
N-1200	Prefilter
N-1201	MERV 8
N-1202	HEPA
N-1203	Carbon Filter
N-125	Foot adjustable

## Condensing Unit Spare Parts

Display/Control	
N-100	Main Control Board
N-101	Display Board
N-102	RH/Temp. Sensor
Internal Components	
N-1209	Compressor
N-1206	Compressor Capacitor
N-1208	Coil Assembly
N-1207	Condensate Pump Assembly

Fan Components	
N-1210	Fan Motor
N-1211	Complete Fan Assembly
N-1205	Fan Capacitor
Filter + External Components	
N-1200	Prefilter
N-1201	MERV 8
N-1202	HEPA
N-1203	Carbon Filter
N-125	Foot adjustable

## Limited Warranty

All warranty benefits apply to the original owner only. Warranty cannot be transferred or assigned.

### 5 Years (From Date of Purchase):

Unipdry warrants the dehumidifier will operate free of defects in workmanship and materials. At its discretion, Unipdry will repair or replace any malfunctioning components, free of charge excluding transportation costs.)

### Customer Responsibilities:

In order to take advantage of the warranty service, the customer must do the following:

1. Customer must provide normal care and maintenance (including, but not limited to cleaning filters, coils and pumps)
2. Removal and re-installation of unit is the sole responsibility of owner.
3. If customer cannot return unit to certified repair center, all costs associated with freight shipment are borne by the customer. In addition, all duties related to freight shipments, including but not limited to palletizing, wrapping, labeling, and pickup are associated with customer.
4. If shipped, customer is responsible for all risk of loss or damage.

### Warranty Procedure:

1. Customer must mail in warranty registration card to Unipdry. If no card is submitted, warranty period will begin the day the shipment left the warehouse. Please be sure to record serial # and date of installation in the spaces provided on page 2 of the manual. You will need this information to receive an RA number.
2. If warranty service is necessary, customer must contact Unipdry Tech Support by phone 888-990-7469 to receive a Return Authorization (RA number).
3. Once an RA has been issued, it is the customer's job to bring the unit to a certified repair center. If this is not an option, shipping will be arranged to bring the unit back to the Unipdry warehouse (at the expense of the customer).
4. After the unit has been received by Unipdry (whether at a repair center or the warehouse), an initial inspection will be completed, if it is determined to be an invalid warranty claim (see exclusions below), unit will only be completed after receiving payment from customer for all associated costs.
5. If unit is defective, the necessary parts will be repaired or replaced and the unit will be available for pickup at certified repair center or returned via freight shipment (at customer's expense). Keep in mind that work is only done during normal working hours. After being repaired, all units are required to go through a rigorous testing process prior to being returned to customer.
6. Once a part is repaired and the dehumidifier is returned, the original warranty period still applies (no extensions)

## Warranty Exclusions

DAMAGE DUE TO THE FOLLOWING IS NOT COVERED UNDER WARRANTY

### 1. ACTS OF NATURE- INCLUDING BUT NOT LIMITED TO:

- FLOODING
- FIRE
- WATER DAMAGE
- HURRICANE/STORM DAMAGE

### 2. IMPROPER USAGE- INCLUDING BUT NOT LIMITED TO:

- POOL/SPA/TUB APPLICATIONS
- MISUSE, ABUSE, OR TAMPERING WHETHER INTENTIONAL OR ACCIDENTAL
- IMPROPER INSTALLATION OR DESIGN
- IMPROPER VOLTAGE
- LACK OF NORMAL CARE
- FAILURE TO FOLLOW INSTRUCTIONS

### 3. CORROSION

### 4. FREEZING

### 5. ANY ADDITIONAL COSTS DUE TO CHANGES IN LAWS OR BUILDING CODES

### 6. FREIGHT CHARGES

### 7. ANY COSTS DUE TO LOST PROFIT OR DELAY

### 8. DAMAGE TO PROPERTY

### 9. CAUSE BEYOND CONTROL

### 10. CONSUMABLE PARTS, INCLUDING BUT NOT LIMITED TO:

- FILTERS
- BATTERIES
- POWER CORDS
- VALVES
- SWITCHES
- RUBBER PARTS

### 11. DIRECT, INDIRECT, COLLATERAL OR INCONSEQUENTIAL DAMAGES OF ANY KIND

THE WARRANTIES AND LIABILITIES SET FORTH ARE IN LIEU OF ALL OTHER WARRANTIES EXPRESSED OR IMPLIED, IN LAW OR IN FACT, INCLUDING IMPLIED WARRANTIES OF MERCHANTABILITY AND FITNESS FOR PARTICULAR PURPOSE. Unipdry's total liability, regardless of nature of claim shall not exceed original purchase price of the product. If a product or component is replaced while under warranty, the applicable warranty period shall not be extended beyond the original warranty time period.

The foregoing shall constitute the total liability of seller in the case of defective performance of all or any of the equipment or services provided to buyer. Buyer agrees to accept and hereby accepts the foregoing as the sole and exclusive remedy for any breach or alleged breach of warranty by seller.

Any dishonesty or fraud in connection with Unipdry warranty thoroughly voids all warranty policies. Unipdry expressly reserves the right to pursue legal action in the event of dishonesty, fraud, or attempted fraud.